

UF250BMB-E Series

Size : $\varnothing 250 \times 72$
Unit : mm

(Axial Fan)

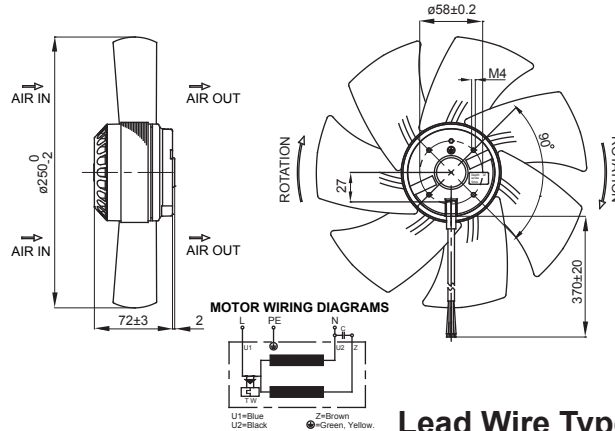
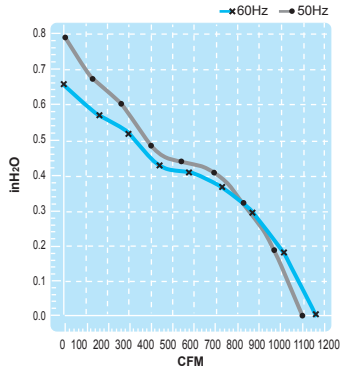

Lead Wire Type



Thermally-Protected



Spec.	Rated Voltage	Frequency	Input Power	Rated Current	Locked Current	Speed	Maximum Air Flow	Maximum Air Flow	Maximum Pressure	Maximum Pressure	Capacitor	Noise	Weight
Model	V	Hz	W	A	A	RPM	m ³ /min.	CFM	mmH ₂ O	InchH ₂ O	μ F/DB	dB	kg
UF250BMB11H1C2E	115	50	112	1.00	1.90	2550	31	1090	20.0	0.78	12/250	68	1.8
		60	148	1.50	1.90	2700	32	1130	16.5	0.65		70	
UF250BMB23H1C2E	230	50	119	0.59	0.91	2550	31	1090	20.0	0.78	4/450	68	1.8
		60	158	0.82	0.91	2700	32	1130	16.5	0.65		70	